

# INSTALLATION INSTRUCTIONS



## Constant Voltage Dimmable LED Driver 20W/40W/60W/96W

### BEFORE YOU START:

- Read and follow all instructions
- Reference local electrical codes
- Mount power supply at a height greater than 1 foot.

### NOTE: 100% to 20% Dimmable.

To ensure good dimming results, the driver requires a minimum load of 10%-100% of total capacity. Working temp is -13F to 104F. Drivers are dimmable with the following dimmers.

### Recommended Dimmers

LUTRON DVLV600  
LUTRON DVCL153

**SAFETY WARNING:** Reference the National Electrical Code regulations. Installation work and electrical wiring should be done by qualified person(s) in accordance with all applicable codes and standards. Modifying or disassembling beyond instructions will void the warranty for this product. Do not submerge or install within 5 feet of a swimming pool. Failure to follow safety warnings, and installation instructions will void the warranty for this product.

### DRY/ DAMP LOCATION ONLY

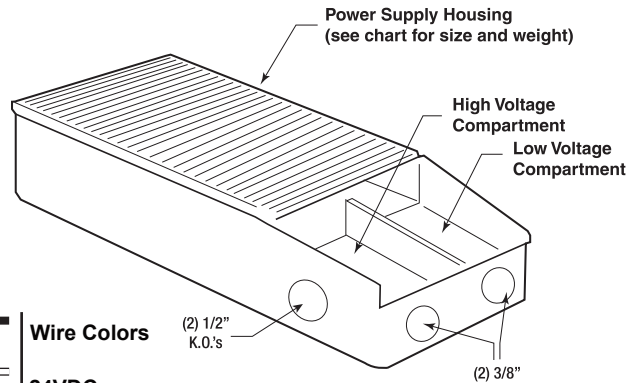

### 120V Wiring

Black (power)

White (Neutral)

Ground

### Wire Colors

24VDC

Red: +

Black: -

FIG. 1

1. Unscrew lid from power supply body and remove. Set aside.
2. Pry open appropriate knock-outs to allow 120V power into power supply.

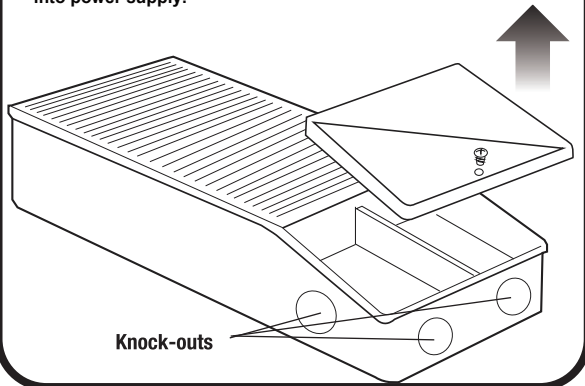
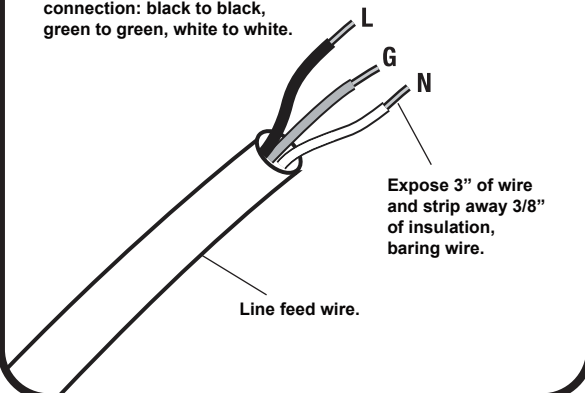

FIG. 2

1. Attach conduit fitting to power supply via knock-outs.
2. Strip wire leads as shown in diagram and make 120V connection: black to black, green to green, white to white.



Model No.	Size	Voltage / Watts	Weights
DL-PS-20/24-JB-DIM-A	6.97"L x 2.76"W x 1.40"H	24V / 20W	0.75 lbs.
DL-PS-40/24-JB-DIM-A	6.97"L x 2.76"W x 1.40"H	24V / 40W	1.3 lbs.
DL-PS-60/24-JB-DIM-A	6.97"L x 2.76"W x 1.40"H	24V / 60W	1.5 lbs.
DL-PS-96/24-JB-DIM-A	6.97"L x 2.76"W x 1.40"H	24V / 96W	1.5 lbs.

To calculate total watts multiply (Watts per ft.) x (Total Length of Run) = Total Watts  
It is recommended to have 10% - 100% loading for optimal performance.

FIG. 3

